

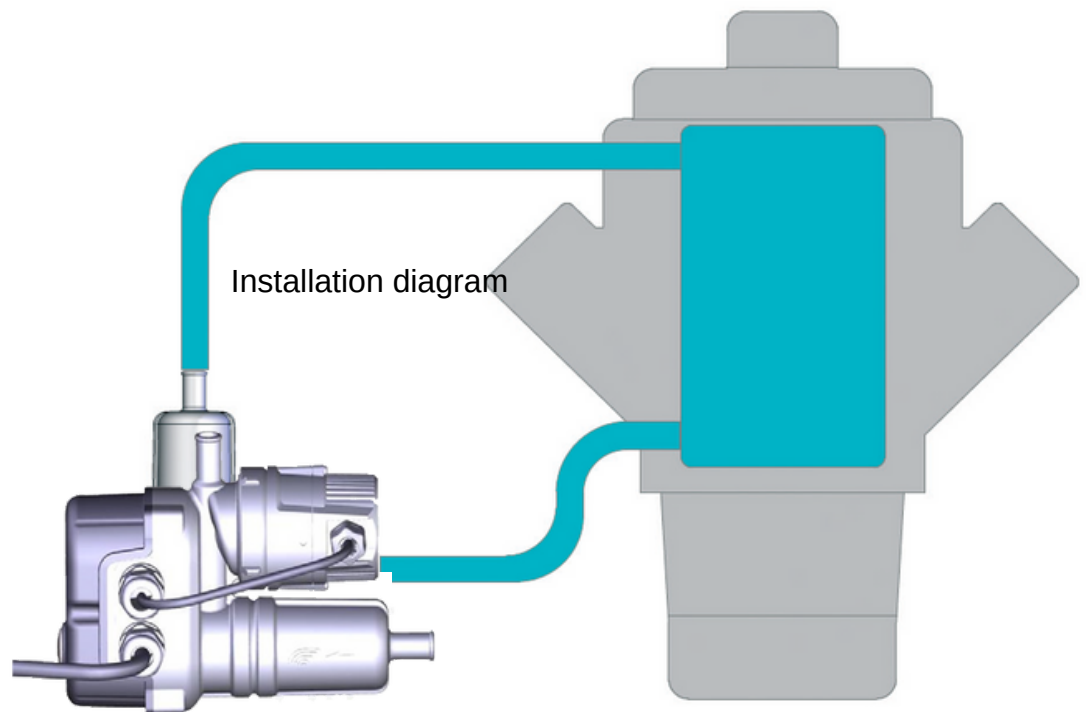

FlowStart

The FlowStart is an electric coolant heater for all types of water-cooled engines. It is universal, reliable, easy to install, and maintenance free. The heater can be put into service a few hours before starting the engine, in order to keep the engine permanently at the required temperature. This ensures an easy full power start whatever the ambient temperature and avoids cold start mechanical damage. This version is suited for all industrial applications, either stationary (generator sets) or mobile (vehicles, vans, trucks, heavy-duty vehicles).

Heating unit <ul style="list-style-type: none"> Aluminum AS9U3 injected heating unit with impregnation treatment PA66 protection covers 200 cm (6,6 ft) power cable Inlet/Outlet: 5/8" (15 mm) hose barb water outlet and inlet 	Circulation pump <ul style="list-style-type: none"> Glandless circulation pump Flow rate: 300L/h @ 1m height manometer (1,3 GPM @ 1,5 PSI) Voltage: 120V to 230V Frequency: 50 Hz and 60 Hz IPX7 ingress protection level available
Water temperature control thermostat <ul style="list-style-type: none"> Fixed thermostat 34-40°C (93-104°F) or 35-50°C (95-122°F), rated 25A, 100.000 cycles 	Heating element <ul style="list-style-type: none"> Low watt density heating element (7,5W / cm², 48W / in² → 1,5kW) Incoloy 800 protection sheet Available powers: 500W, 1000W, 1500W, 2000W Available voltages: 120V or 230V
Safety thermostat <ul style="list-style-type: none"> Security thermostat 110 °C with manual reset, rated 25A, 6.000 cycles 	

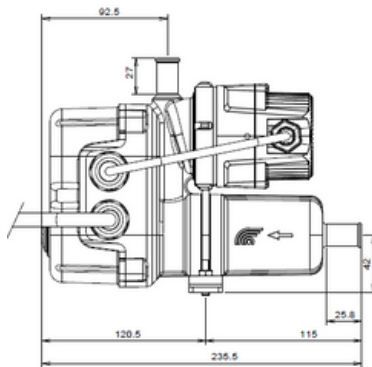
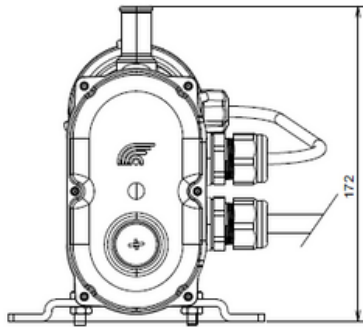
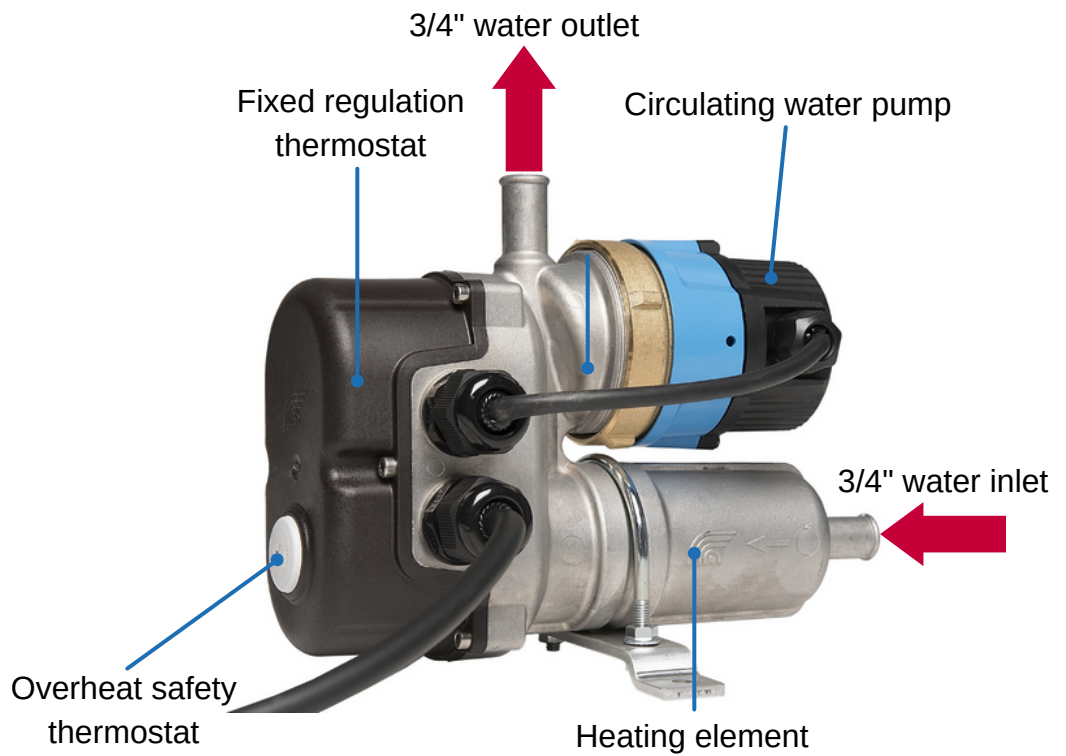
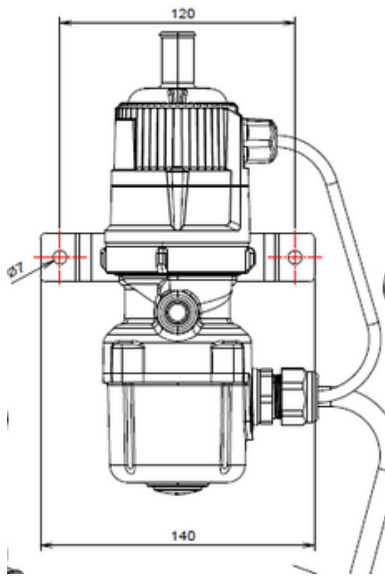

Your PowerHeat Partner:



Unit 21 Park Farm Business Park
Skeffington
Leicestershire
LE7 9FN

+441664 668599
sales@genheat.co.uk
www.genheat.co.uk

PowerHeat B.V.
Robijn 930, 3316 KE
Dordrecht, the Netherlands



+31 (0)85 0709430
post@powerheat.nl
www.powerheat.nl